

Step - 1

Position two Deck Clamps onto rib and tighten wing bolt. (Ensure jaws are located firmly on underside of rib.)

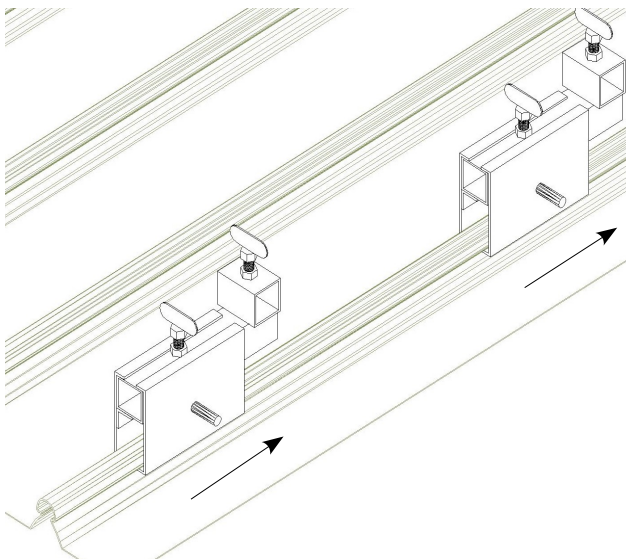

Step - 2

Slide the Support Bar into both Deck Clamps and tighten wing bolts.

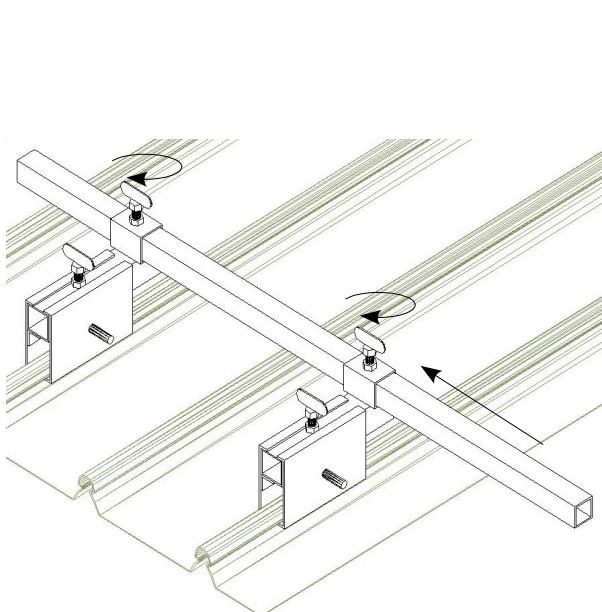

Clamp On Rail(Gable)

Step – 3

Slide Bottom post onto the support bar and tighten wing bolt.

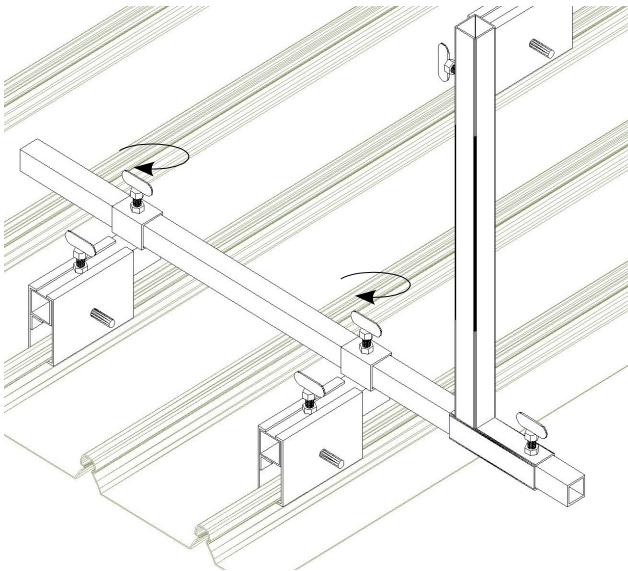

Step - 4

Slide the 2D post into the Bottom Post and tighten wing bolt. Make sure " D's " are facing working area.

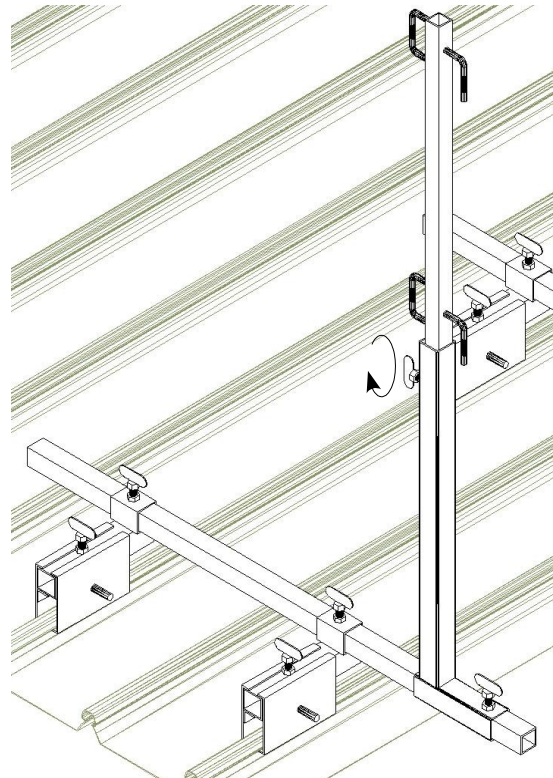

Step – 5

Slide the 3rd rail clamp on the Bottom Post 'L' and tighten the L bolt. (Note: min. and max. from roof surface)
Make sure rail "D" is facing working area.

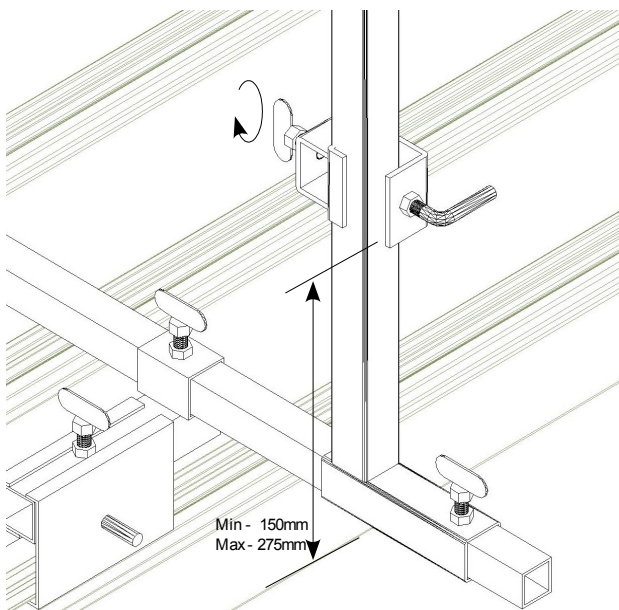

Step – 6

Slide the rails into 2D post and 3rd rail clamp and Tighten the L bolts.

